

BN Thermic Ltd

34 Stephenson Way
Three Bridges,
Crawley,
West Sussex RH10 1TN
England

Tel: +44 (0)1293 547361

Fax: +44 (0)1293 531432

BN thermic

BNTMLH03

LH

Underfloor Heating Film

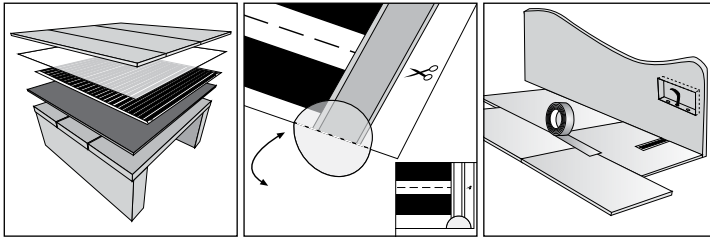

COMPLETE INSTALLATION INSTRUCTIONS & GUARANTEE

the complete electric underfloor heating
solution for wood and laminate floors

Congratulations on your purchase of LH Underfloor Heating, the Ideal solution for heating laminate and engineered wood floor coverings.

Please read the following Instructions carefully to ensure ease of Installation. Remember that the final electrical connections must be made by a qualified electrician and also that the guarantee certificate must be filled in and signed by the electrician to ensure you are covered by our ten year guarantee.

Typical installations:

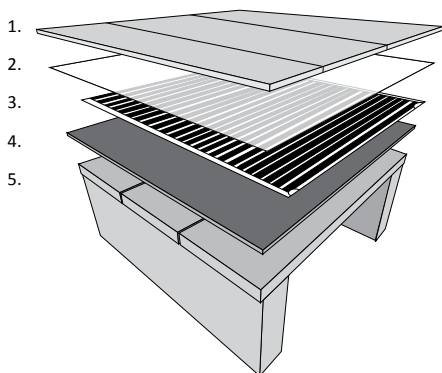

1. Engineered wood/laminate floor
2. VB Vapour Barrier
3. LH Heating Films
4. DEP6 Insulation
5. Suspended Timber Floor

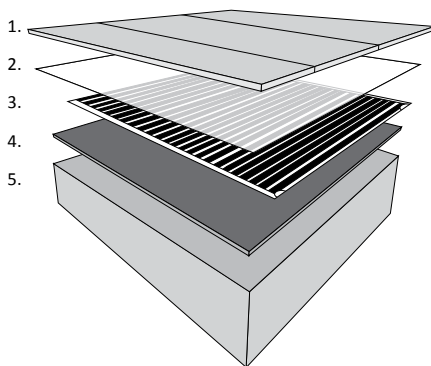

1. Engineered wood/laminate floor
2. VB Vapour Barrier
3. LH Heating Films
4. DEP6 Insulation
5. Concrete Sub-floor

Please take time to read carefully the following notes and instructions before commencing installation:

- LH underfloor heating systems are designed to be used under laminate and engineered wood flooring with a maximum thickness of 15mm (or thickness equivalent to a maximum thermal resistance of $0.15\text{m}^2\text{K/W}$). When underlay is specified by the manufacturer this may reduce the thickness of flooring permitted. Always check to ensure the flooring is suitable for use with underfloor heating systems.
- LH underfloor heating systems operate on a standard 230 Volts mains electrical supply. Please check all films are the correct voltage and power rating.
- LH underfloor heating systems are designed for simple “do it yourself” installation, however all electrical connections must be done by a qualified electrician and the complete installation must comply with BS 7671 :2001 (IEE Wiring Regulations) and Part P of The Building Regulations.
- LH underfloor heating systems must be protected by a 30mA RCD (residual current device) and a suitably rated fuse or MCB (miniature circuit breaker).
- LH must only be installed in dry locations.
- LH underfloor heating films must not be installed below fixed pieces of solid furniture, cupboards, wardrobes etc as this could lead to a local increase in temperature.
- Thick rugs, dog beds, bean bags etc must not be laid on the heated floor as this may cause localised overheating and damage the floor covering.
- Care must be taken to ensure the LH heating films are not damaged during installation. It is advisable to lay the floor immediately after installation.
- LH heating elements must be protected by VB polyester vapour barrier.
- LH underfloor heating systems are designed to be controlled by BN Thermic’s approved range of thermostats. If the installed load exceeds the switching capacity of the selected thermostat then a suitable contactor must be installed by the electrician.
- LHT High Specification Fixing Tape must be used for installation of the DEP6 thermal insulation, LH heating films and VB vapour barrier.

Thermostat

The selected **BN Thermic** thermostat should be positioned (fig. 1) at a height approximately 1.5m from the floor in an area free from draughts, out of direct sunlight and close to the electrical supply. All **BN Thermic** thermostats have a floor sensor which is placed in the supplied protective plastic conduit and positioned centrally below one of the heating elements at a distance of approximately 0.5m from the wall. A single gang flush fitting minimum 25mm deep back box (35mm preferred) will be required for the controller.

Junction Box Installation

A junction box (fig.1, preferably 2 gang x minimum 25mm deep) is required for commoning up the LH heating film's 4m long connection leads. This should be sited close to the thermostat and in a position to enable all the connection leads and the thermostat sensor conduit to reach the box comfortably.

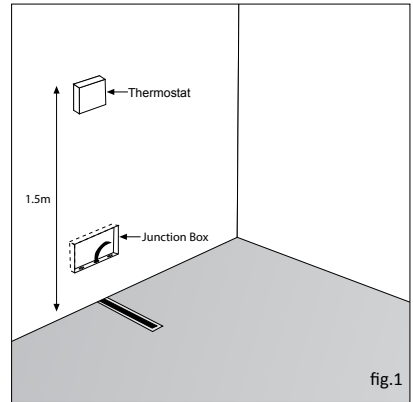

Floor Sensor Installation

Cut a 13mm wide by 6-7mm deep channel in the subfloor (fig.2) to accommodate the sensor conduit so that top of the conduit will be level with the DEP6 thermal insulation surface when installed (see fig. 2). Tape over the end of the conduit using a small piece of LHT fixing tape. Place the conduit in the channel and feed the end into the junction box. The conduit can now be cut to length leaving approximately 5cm inside the junction box. Slide the sensor into the conduit until the sensor bulb reaches the taped end. Wrap a piece of tape around the conduit and sensor cable to prevent the sensor being accidentally pulled out. Use LHT fixing tape to hold the conduit in place in the channel.

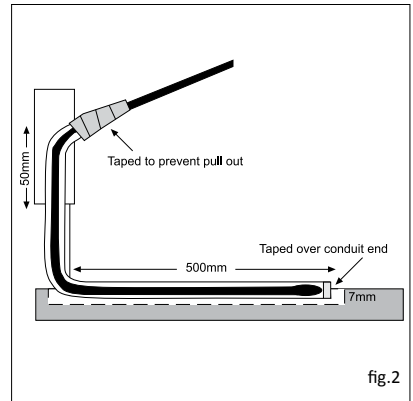

Laying The DEP6 Thermal Insulation

Thoroughly clean the existing floor area taking care to remove any sharp objects.

Lay the DEP6 sheets in "brick work" fashion as illustrated in the drawing (fig.3). Always remember to cover the total floor area with DEP6 even unheated areas. Tape along the edges using LHT fixing tape. Carefully cut a channel in the DEP6 at the position of the sensor conduit channel using a sharp knife and straight edge. Tape over the conduit using LHT fixing tape.

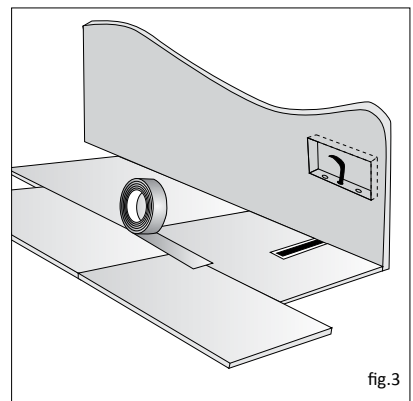

Laying the LH Heating Film

Before commencing check the labels on each of the LH film cartons to ensure they are the correct sizes and power rating.

Following the plan prepared at the ordering stage and working from one side, rollout the first element copper side down with the connection leads closest to the thermostat wall and leaving a minimum 50mm gap from walls. Apply light finger pressure on the cable connection covers to leave an imprint on the DEP6, move the film to avoid damage and using a sharp knife remove the DEP6 to allow the cable connection cover to sit flush with the DEP6 surface (fig.4).

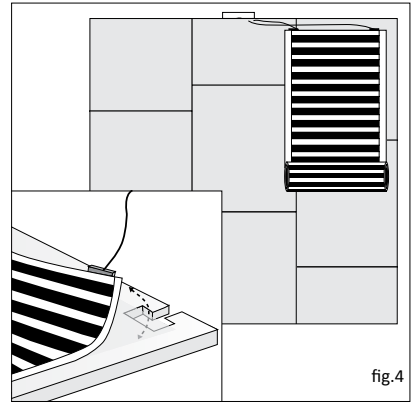

fig.4

Adjusting the LH Films

LH heating films are available in standard lengths from 2.0m to 10m. Should the elements require to be shortened this can be easily done by cutting along the cutting line using a sharp knife and straight edge or scissors and insulating the copper strips using the insulating green polyester tape discs (4 off supplied with each LH film) as shown in the diagram (fig.5). Care should be taken not to cut closer than 3mm from the edge of the black heated area. Repeat the procedure for the remaining films, butting adjacent films edge to edge.

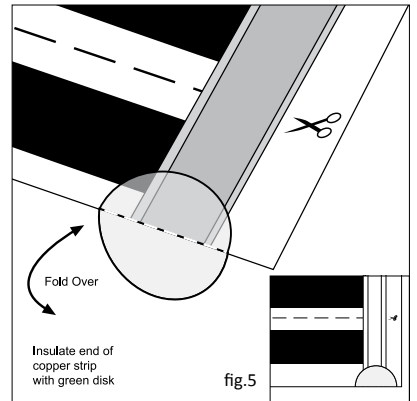
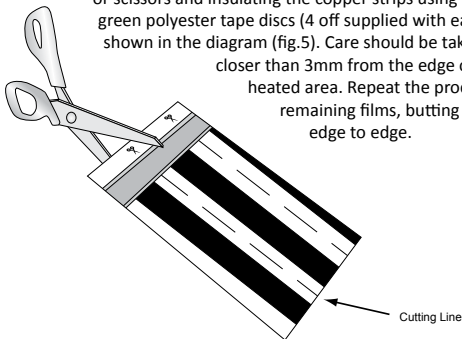

fig.5

Taping the LH Heating Films

Tape along the edges of the LH heating films using the LHT fixing tape taking care not to damage the heating films.

Using a sharp knife, cut a channel in the DEP6 along the connection lead/thermostat wall side to accommodate the connection leads (fig.6). Run the leads in the channel to the junction box and tape over using LHT fixing tape.

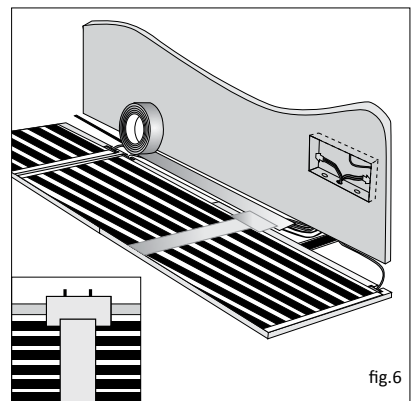
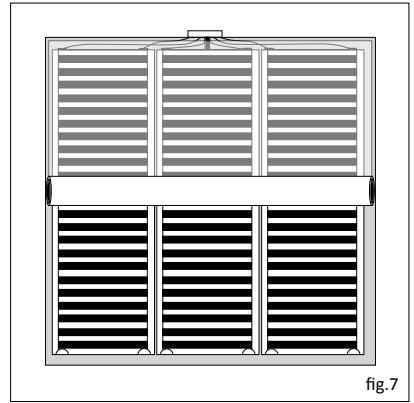

fig.6

Laying VB Vapour Barrier

The installed LH heating films must be covered with the VB Vapour Barrier to provide optimum moisture and additional mechanical protection.

The entire floor must be covered including unheated areas. Adjacent sheets must overlap by a minimum of 100mm. The entire length of the overlap must be taped using LHT fixing tape.



Making The Connections

Please note the following steps must only be carried out by a qualified electrician

Using the graph paper supplied draw a sketch showing the approximate position, width and length of each LH film together with the temperature controller sensor position and number each of the films on the drawing.

LH heating films are connected together using the lever action LHC connector. A separate connector is used for the live and neutral connections. A single pair of connectors will connect up to 4 heating films to the thermostat output (fig.9). To connect up to 7 films, 2 pairs of connectors will be required with each pair being connected together using a suitable link wire - maximum 2.5mm² solid or up to 4mm² fine stranded cable (fig.9).

Cut the cables inside the junction box to approximately 100mm. Carefully strip back 10mm of the cable insulation taking care to completely remove the clear inner insulation.

Measure and record on the test sheet the resistance of each film and carefully insert all brown and blue cables into separate commoning blocks as shown in the diagram (fig.8). A suitable cable (maximum 2.5mm² solid) will be required to connect the commoning blocks to the output of the thermostat.

Please note: if the installed load exceeds the thermostat power rating then a suitable contactor must be used.

Measure and record the total installed load resistance and carry out an insulation check to ensure no damage to the heating films has occurred during installation. A second insulation resistance measurement should be taken once the flooring has been laid. Both measurements should be at least 10M Ohms.

Finally, complete the test report and guarantee certificate ensuring all measurements are correctly recorded and leave all documentation including the thermostat instructions next to the electrical supply distribution board.

Remember the guarantee must be filled in and kept with a proof of purchase to ensure you are covered by our ten year guarantee.

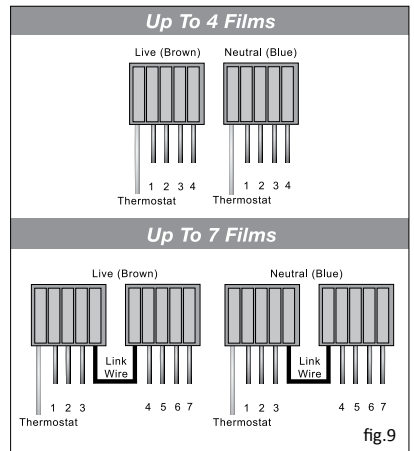
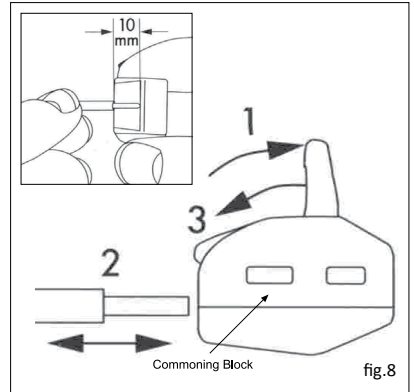

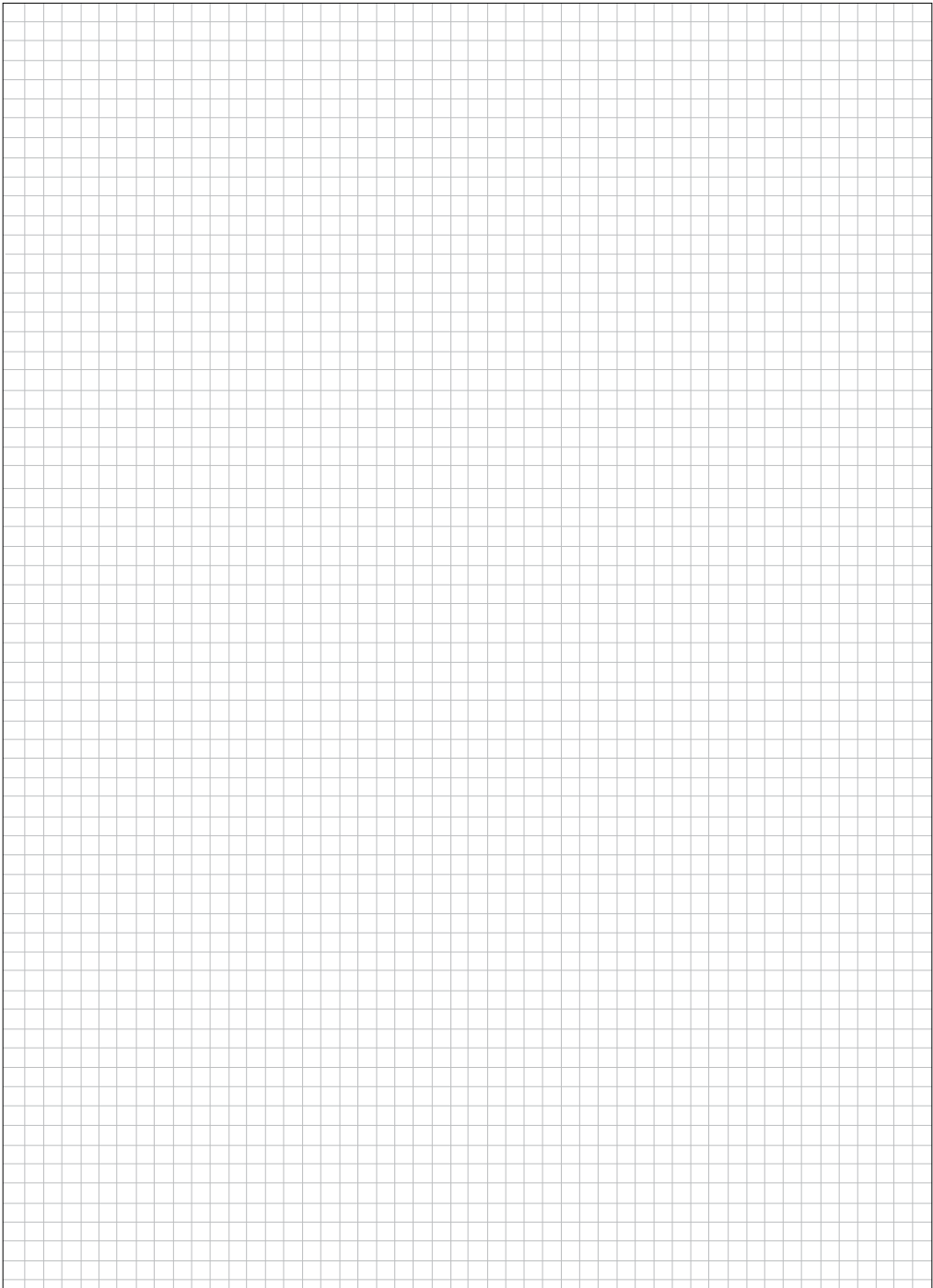

Please remember to number the films on the diagram



BN *thermic*

GUARANTEE CERTIFICATE

LH

Underfloor Heating Film

This guarantee is only valid under the following conditions:

- All electrical connections were connected by a qualified electrician
- The guarantee covers faults in material for 10 years for LH heating films and 1 year for other components from the date of purchase.
- The completed guarantee and proof of purchase must be presented in connection with warranty claims.
- The guarantee covers the repair/replacement of goods found to be faulty and does not cover secondary charges relating the repair/replacement of any floor covering.
- The BN Thermic warranty does not cover faults resulting from incorrect design or installation or damage caused by others.

Element Number	Installed Length (m)	Measured Resistance (Ohms)
Total Load Resistance (Ohms)		

Insulation Resistance	
Before Laying Floor (MΩ)	After Laying Floor (MΩ)

Address of installation

.....

Postcode

.....

Electrical installation by (Company Name)

Signed

Print name

Date

.....

Please contact BN Thermic for a full list of terms and conditions.

BN Thermic Ltd
34 Stephenson Way
Three Bridges,
Crawley,
West Sussex RH10 1TN
England

Tel: +44 (0)1293 547361

Fax: +44 (0)1293 531432